

## OPERATING INSTRUCTIONS

# MBA 200

## Rotating Bin-Level Indicator



**Installation**  
**Operation**  
**Maintenance**



## Document information

Document ID  
 Title: Operating Instructions MBA 200  
 Order No.: 8011417  
 Version: 2.2  
 Stand: 2009-05

Subject  
 Product name: MBA 200  
 Hardware: all versions

Manufacturer  
 MBA Instruments GmbH  
 Friedrich-List-Str. 5 · 25451 Quickborn · Germany

© MBA Instruments GmbH Germany. All rights reserved.

## Explanation of warning symbols



Hazard (general)



Hazard by voltage



Hazard in explosion-hazardous locations



Hazard by high temperature or hot surface

## Warning levels

### CAUTION

Hazard or unsafe practice which could result in personal injury or property damage.

### WARNING

Risk or hazardous situation which could result in severe personal injury or death.

## Explanation of information symbols



Technical risk for this device or its function (general)



Technical risk for this device by voltage or other electrical hazards



Supplementary information



Nice to know

## Contents

<b>1</b>	<b>Product overview</b>	3
<b>2</b>	<b>Product description</b>	4
2.1	Unit components	4
2.2	Principle of operation	4
2.3	Optional equipment	4
2.4	Appropriate use	4
2.5	Responsibility of the user	4
<b>3</b>	<b>Installation</b>	5
3.1	Protective roof / deflector	5
3.2	Assembly (if required)	5
3.3	Installation	6
3.3.1	Operational conditions	6
3.3.2	Installation position	6
3.3.3	Attachment	6
3.3.4	Temperatures of the distance tube	7
3.4	Electrical connection	7
3.4.1	Important safety notes	7
3.4.2	Safe electrical installation	7
3.4.3	Protection against explosion	7
3.4.4	Type 210 (115 or 230 VAC)	8
3.4.5	Type 220 (24 VAC/DC)	8
3.4.6	Type 230 (42/115/230 VAC)	9
3.5	DIP switch settings for type 220/230	9
3.6	Closing the housing	9
3.6.1	Closing the cable glands	9
3.6.2	Closing the cover	9
<b>4</b>	<b>First Start-up</b>	10
4.1	Switching on	10
4.2	Function test at first start-up	10
4.2.1	Check the operative function	10
4.2.2	Check for triggering by the bulk material	10
<b>5</b>	<b>Maintenance</b>	10
5.1	Recommended maintenance work	10
5.2	Preventive function check	10
5.3	Safety information on opening	10
5.4	Removing the unit head (repair note)	10
<b>6</b>	<b>Fault indication</b>	11
<b>7</b>	<b>Technical data</b>	11
7.1	Specifications on the nameplate	11
7.2	Electrical data	11
7.3	Ambient conditions	11
7.4	Product materials	11
7.5	Dimensions	12
7.6	EC-Type Examination Certificate	13

# 1 Product overview

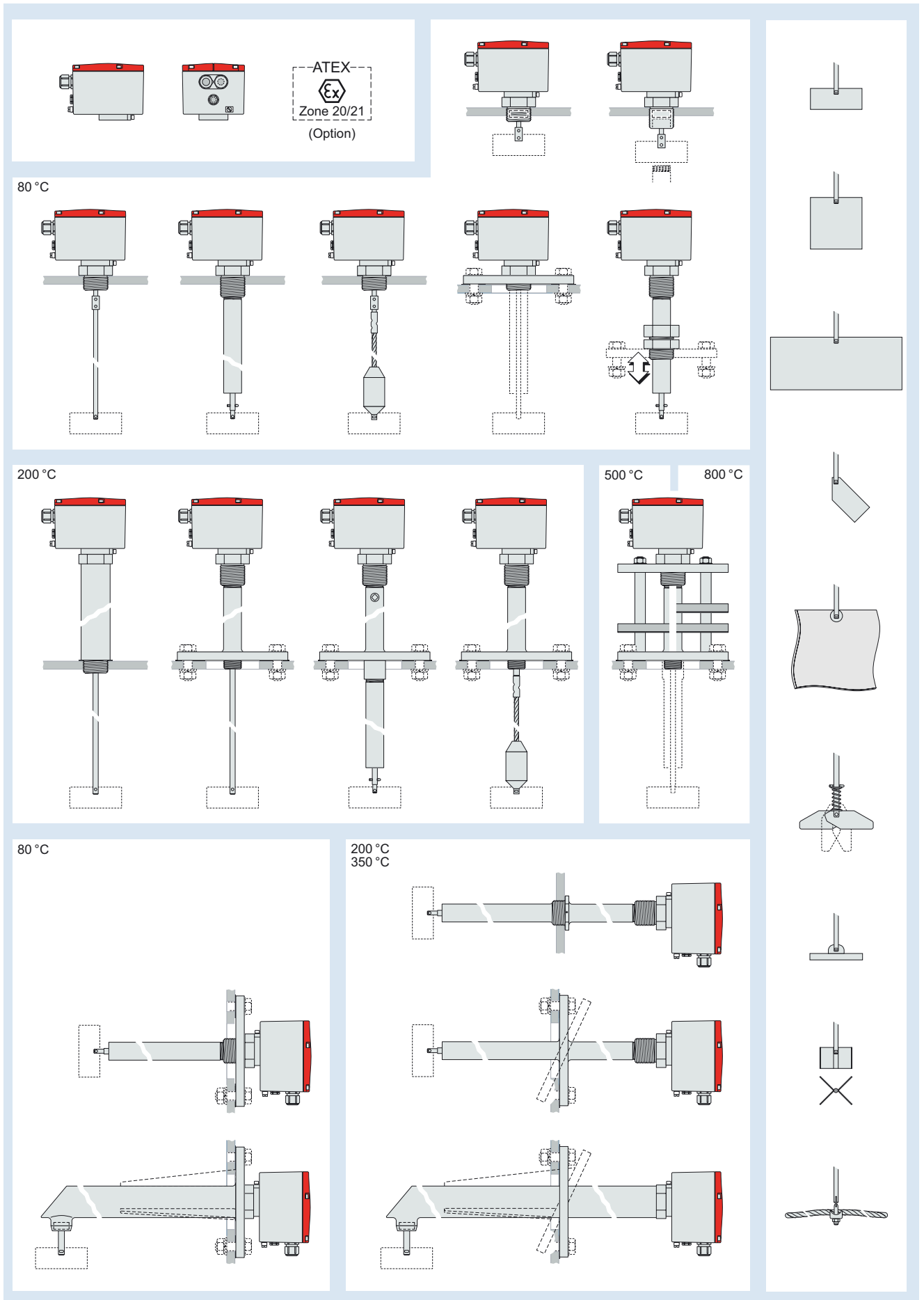

## 2 Product description

### 2.1 Unit components

1. **Unit head:** contains the motor drive and electronic components. Three different types available.
2. **Process connection:** thread or flange. Attached to the outer wall of the bulk materials container. Holds the unit head on the outside and the protective tube (if provided) on the inside. Many versions available for individual adaptation to the actual container.
3. **Shaft:** Connects the paddle to the unit head. Various lengths available (large sizes divided in two sections) and a flexible steel cable as the shaft.
4. **Paddle:** Stops the shaft rotation when the bulk material surrounds the paddle. Solid/flexible/foldable versions available with different size or material.
5. **Protective tube (option):** Covers the shaft inside the container. Various lengths available. Versions: open tube for vertical mounting (great lengths delivered in two sections); tube for horizontal mounting with additional shaft bearing at the end; angled shaft bearing with horizontal tube and a vertical shaft.

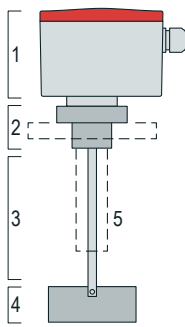

### 2.2 Principle of operation

The electric motor in the head makes the shaft and the paddle rotate slowly. When the bulk material surrounds the paddle, the rotation is blocked. The counter-torque is used to turn the motor mechanism against a switch which then turns the motor off. The switch has a second contact (potential-free) which is used for the status indication.

As soon as the bulk material releases the paddle again, a spring pulls the motor mechanism back into the working position. Thus the switch is released and the paddle starts rotating again.



The motor mechanism requires approximately 3 seconds to indicate stopping or restarting of the paddle (switching delay due to the mechanical sequence).

Additional indication delay can be effected by

- the characteristics of the bulk material
- torsion effects (e.g. cable shaft, rubber paddle)
- electronic switching delay (→ page 9, § 3.5)

### 2.3 Optional equipment

#### General options

- **Special seal (DTR):** Protection against gases, vapours, and abrasive bulk materials.
- **Compensating membrane:** Membrane which allows diffusion of water-vapour and thus can balance out the humidity inside the unit head. Moreover, the membrane will burst if the pressure inside the unit head increases strongly due to operational trouble, which allows the use on containers with an internal pressure up to +1 MPa (option »10 bar«).
- **Heating in the unit head:** Allows use at low ambient temperatures.
- **Height adjustment:** A clamping sleeve which guides the protective tube of the extension arm and allows fixing the extension arm at variable insertion depth.

#### Electronic options (only for type 220 and 230)

- **Action monitoring:** A Hall sensor in the unit head monitors the shaft rotation. The error status is indicated by means of a relay contact.
- **Indicating LED light:** Indicates the current status.

### 2.4 Appropriate use

#### Range of application

MBA bin level indicators are rugged electromechanical sensors, designed to detect the presence of bulk material at the place of installation and thus to control the filling of bulk material containers. Possible applications depend on the configuration of the individual unit.

Bin level indicators of the MBA 200 series can be used with industrial bulk materials from organic and mineral substances. MBA units may not be affected by chemical aggressive gases or fluids.



#### WARNING: Explosion hazard

A MBA 200 bin level indicator may only be used in explosion-hazardous locations if the individual specifications of the unit complies with this use.

- ▶ Check nameplate and accompanying papers.
- ▶ Check whether the specifications of the EC-Type Examination Certificate must be complied with (→ page 13, § 7.6).



- ▶ *If there is any doubt whether the unit may be used for the desired application or not: Ask the manufacturer.*

#### Design options

Variable design features are, for example:

- Paddle design, size, and material
- Shaft design and material
- Sealing of shaft against enclosure

The corresponding properties for the unit can expand or restrict the range of possible applications (e.g. suitability for a particular type of bulk material). Please note carefully the specifications for your particular unit.

### 2.5 Responsibility of the user

- ▶ Use the device only as described in these Operating Instructions. The manufacturer bears no responsibility for any other use.
- ▶ In addition to these Operating Instructions, follow all local laws, technical rules and company-internal operating directives applicable at the respective installation site of the equipment.
- ▶ No components may be removed from, added to or changed on the device unless this is described and specified in the official manufacturer information.
- ▶ *In explosion-hazardous locations:* Prior to installation and operation, observe the European standard EN 61241-14.



EN 61241-14: Electrical apparatus for use in the presence of combustible dust – selection and installation.s

Product versions which are certified for use in explosion-hazardous locations have been tested and certified according to EN 61241-0 and EN 61241-1.

### 3 Installation



▶ Do not remove, add, or change any of the components in the instrument unless these changes are described and specified in a manufacturer's official information. Otherwise the manufacturer's guarantee becomes invalid, and the certification for use in explosion-hazardous locations (if provided) is no longer valid.

#### 3.1 Protective roof / deflector

▶ If at all possible, place the MaihakMBA unit in a position where falling bulk material will not directly strike onto the shaft or the paddle.

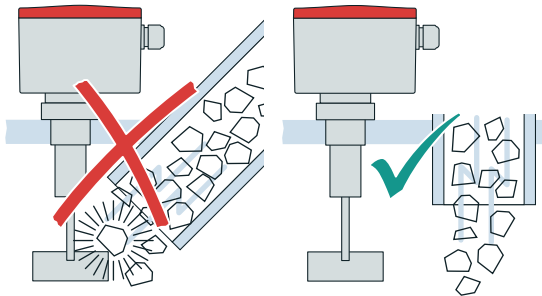

*For heavy bulk materials that could damage the shaft or the paddle:*

▶ If required, install a stable deflector or protective roof in the container which protects the shaft and the paddle against direct impact of falling bulk material.

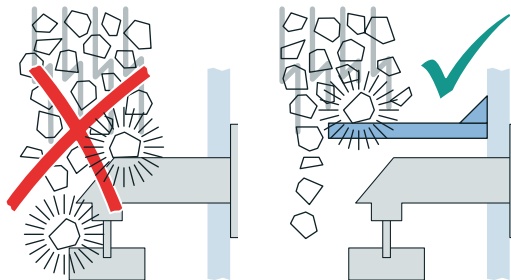

*If the bulk material is heavy or can form large clumps:*

▶ Install a stable protective roof within the container to shield the shaft (and the extension arm) from the weight of the bulk material.  
 ▶ Provide sufficient space between protective roof and paddle to make sure that the bulk material can reach the paddle.

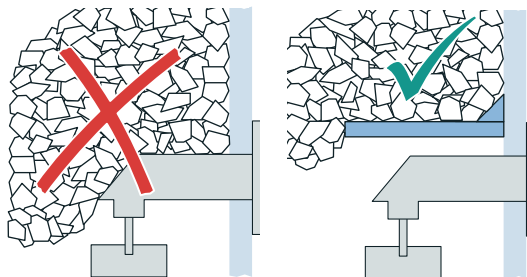

#### 3.2 Assembly (if required)

If shaft, paddle, and protective tube (if provided) were shipped dismantled (for safe and easy transport):

- ▶ **Install the shaft:** Guide the top end of the shaft into the shaft sleeve of the unit head. Use a split-pin to connect both parts (push it through and spread it out). – With two-part shafts: Join both parts of the shaft in the same way.
- ▶ **Assembling the protective tube** (for divided protective tubes): Take the locking screws out of the connecting coupling sleeve. Screw one of the protective tube parts into the coupling sleeve – up to about the middle of the coupling sleeve. Then screw-in the other part from the other side and firmly attach both parts of the protective tube. – *Recommendation:* Now make two small countersunk holes in the coupling sleeve, which will fix the position of the locking screws (use a max. 3.2 mm diameter drill guided through the screw holes of the coupling sleeve). – Put in the locking screws and tighten.
- ▶ **Install the protective tube** (for units with a protective tube): Apply a threadlocking adhesive (such as »Loctite«) to the thread of the protective tube and screw the protective tube into the threaded sleeve, as far as it goes.
- ▶ **Shortening the flexible cable shaft** (if required): Remove the tensioning weight from the end of the cable (undo the locking screw and pull out the cable). At the place where the cable must be cut, wrap some adhesive tape firmly around the cable, to protect against wire particles shooting from the cable. Wear protective goggles/glasses. Then cut the cable with a suitable wire cutter or a cutting disk. Remove the adhesive tape and attach the tensioning weight again.
- ▶ **Install the paddle:** Guide the flat end of the paddle into the slot of the shaft and attach it with the split-pin provided (push it through and spread it out).

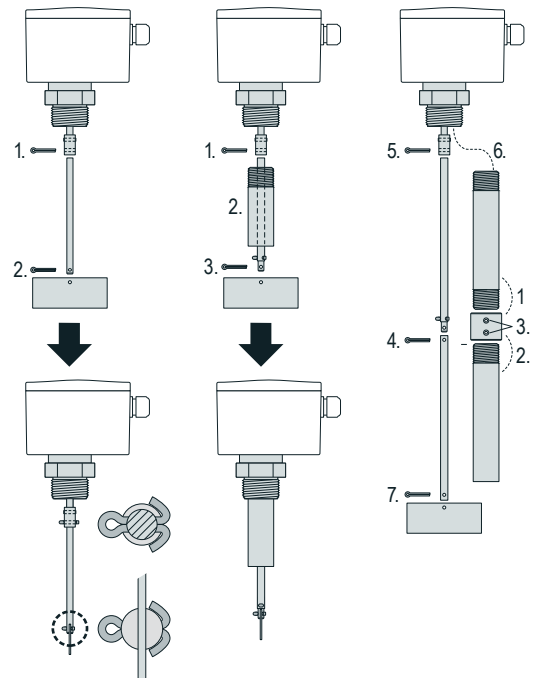

1 ... 7 = order of assembly



- It may be necessary (or advantageous) to install the paddle at the very end of the installation procedure.
- *Recommendation:* Apply a threadlocking adhesive (such as »Loctite«) to all the locking screws.

### 3.3 Installation

#### 3.3.1 Operational conditions

- ▶ Observe temperature specifications on the nameplate (example → page 11, § 7.1, explanations → page 4, § 2.4).
- ▶ Keep the following pressure limits:

Standard configuration	-50 ... +300 kPa (-0.5 ... +3.0 bar)
Version D10 (equipped with burst membrane in the unit head)	max. 1.0 MPa (10 bar)
In explosion-hazardous locations	80 ... 110 kPa (0.8 ... +1.1 bar)

#### 3.3.2 Installation position

- ▶ *Units without additional shaft bearing in the extension arm:* Use only with a vertically suspended shaft ( $\pm 5^\circ$ ).

Exception: If the shaft is rigid (not flexible) and not longer than 200 mm and the bulk material is light-weighted, an angle of inclination of max.  $90^\circ$  is permissible (allows side-mounting with horizontal shaft).

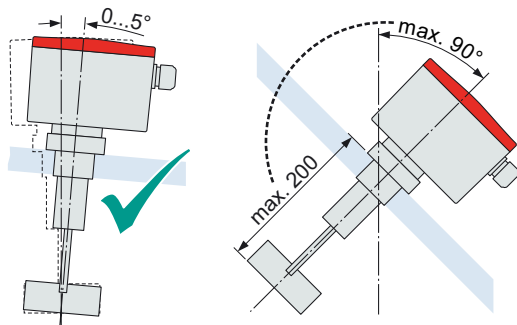

- ▶ *In case of lateral installation (horizontal shaft):* Install the unit in such a way that the cable glands are on the underside of the housing.

The unit head can be turned (2) after the clamping screw (1) on the underside has been released.

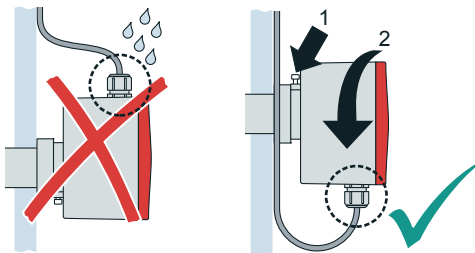

The clamping screw must be fixed to achieve operational condition.

### 3.3.3 Attachment

#### Standard versions

- ▶ Attach the MBA process connection to the container. (dimensions → page 12, § 7.5).
- ▶ *If protection class IP 65 is required (European standard EN 60529):* Provide a suitable water/dust sealing between device and container.
- ▶ *If the paddle does not go through the container opening:* Detach the paddle before mounting and re-install after mounting.

#### Height adjustment (option)

The height adjustment device is a clamp-ring fitting which allows to fix the protective tube at variable insertion depth.

1. Install the threaded base part of the fitting in the container wall.
2. Put the clamping nut and the clamping ring over the protective tube.
3. Guide the protective tube through the base part of the fitting (caution: do not damage the sealing rings inside the fitting) and bring it into the desired position.
4. Guide the clamping ring into the fitting. Screw-up and tighten the clamping nut.
5. Install the paddle.

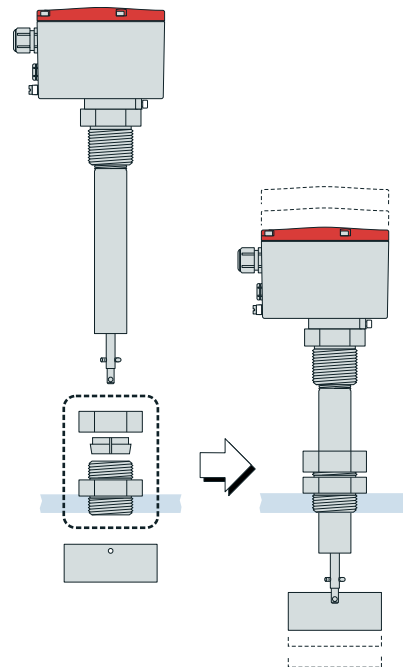

#### Temperature protection by height adjustment

The height adjustment device can also be used to keep the unit head away from high container temperatures.

- *Important:* This feature applies only to units equipped with »DTR« type bearings.

Mounting instructions:

- ▶ Adjust the height to a level where the distance between unit head and container is at least 200 mm (7.9").
- ▶ *If the container is equipped with a thermal insulation:* Remove the thermal insulation around the protective tube (instructions → page 7, § 3.3.4).

When these conditions are kept, the unit can be used with container temperatures up to 200 °C (392 °F).

### 3.3.4 Temperatures of the distance tube

Unit versions for high container temperatures above 80 °C are equipped with a distance tube between unit head and connection thread/flange. The purpose of the distance tube is to keep high temperatures away from the unit head (max. 60 °C).

► *If the container is equipped with a thermal insulation:* Keep the distance tube free of thermal insulation, in order to allow cooling by the ambient air. *Do not* cover the distance tube with the insulation of the container.

Otherwise distance tube will not provide the required cooling effect. Overheat can cause malfunctions and damage the unit head.

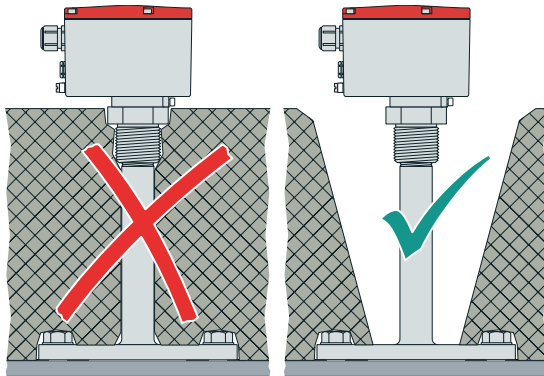

#### WARNUNG: Risk of injury

The distance tube is possibly hot enough to burn skin immediately when being touched.

► *If the container is hot:* Protect the distance tube against accidental touching.



#### WARNUNG: Explosion hazard by dust contamination

The surface temperature of the distance tube can be significantly higher than the unit head temperature.

► Check if the dust-explosion limit value can be exceeded when the surface of the distance tube is covered with dust.

► *If this hazard exists:* Make sure that the distance tube cannot be contaminated with dust, or that the distance tube is periodically cleaned as a preventive measure.

## 3.4 Electrical connection

### 3.4.1 Important safety notes



#### WARNUNG: Free electrical contacts inside the unit head

Before opening the unit head, shut off the mains power supply and all connected signal voltage. The electrical circuits inside the unit head are not protected against physical contact.



#### WARNUNG: High voltage inside the unit head (type 230)

In the type 230 unit head, there are always contacts with an output of 230 and 115 V, even if the unit is powered with a lower voltage (→ page 9, § 3.4.6).

► Observe this information when operating the unit with open unit head for service purposes. Take care. Give a warning to other persons.

### 3.4.2 Safe electrical installation



► A MBA 200 should be installed and set-up by skilled persons who can assess the tasks given and consider the dangers involved.



The MBA 200 is not equipped with a power switch or fuse.

► Install an external power switch which can switch on and off the mains power supply to the MBA 200.

► Provide an external mains fuse for the MBA 200 (power consumption → page 11, § 7.2).

► Use power cable with following conductor cross sections:

- Massive wire: max. 2,5 mm<sup>2</sup>
- Stranded wire: max. 1,5 mm<sup>2</sup>

► Use cables which are specified for an ambient temperature of at least 60 °C (140 °F).

► Protect all cables against heat. Avoid contact with hot surfaces (for example, the container wall). Consider thermal radiation and heat accumulation.

### 3.4.3 Protection against explosion



#### WARNUNG: Explosion hazard

If the unit is used in an explosion-hazardous location, the following criteria must be observed:

► *Certification:*

- Check if the individual unit is applicable to the use in the actual explosion-hazardous location (see nameplate and delivered documents).
- Observe the „special conditions“ which are specified in certification documents.

► *Equipotential connection:* In addition to the protective earth connection (PE), install an equipotential bonding, using the terminal on the outside of the unit head.

► *Cables:* Use only cables which fit to the cable glands. For standard product versions, the outer diameter of the cables must be 6 ... 12 mm.

► *Cable glands:* The built-in cable glands may only be replaced by components which are certified for the use in the actual explosion-hazardous location (ATEX-certified).

► *Fixed installation:* Fix all connected cables in place over their entire length.

► *Sparks:* Prevent generation of sparks inside the container. Sparks can be generated when the shaft or the paddle collides with metal parts. If the MaihakMBA is equipped with a flexible shaft, sparks could be produced when the shaft cable swings and the paddle collides with the container wall.

► *Installation standard:* Make the installation in accordance to the European standard EN 61241-14.

## 3.4.4 Type 210 (115 or 230 VAC)

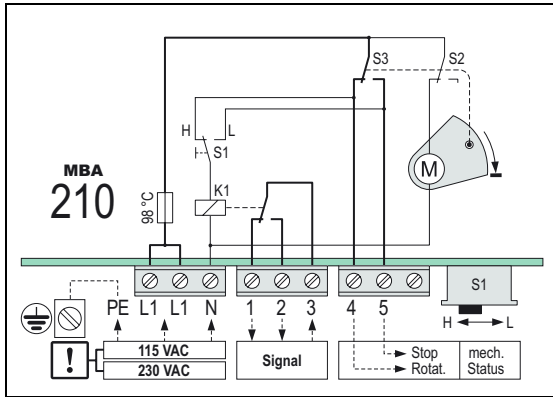
**Signal contact**

- ▶ Use the potential-free make&break relay contact K1 for the level indication.

Depending on setting of S1, relay K1 is activated either when the paddle is rotating or when the paddle is stopped.

- ▶ Select which setting provides a fail-safe operation in your system:

	Position H	Position L
S1	Fail-safe FULL level indication: K1 is activated when the paddle is rotating. During power failure, the »full« status is indicated (like paddle is stopped).	Fail-safe EMPTY level indication: K1 is activated when the paddle is stopped. During power failure, the »empty« status is indicated (like paddle is rotating).

**Status output**

S3 switches the power voltage (L1) between terminal 4 and 5, directly actuated by the motor mechanism.

**Permissible contact load**

Direct current: 60 VDC, 1 A (DC 1)  
Alternating current: 250 VAC, 2 A (AC 15)

**Power supply**

Mains supply voltage: 115 VAC or 230 VAC  
(see nameplate)  
-15 %/+10 %

- ▶ Connect the power supply to terminals L1 and N.
- ▶ Connect the protective earth (PE) conductor to the terminal in the unit head.



Overvoltage can immediately destroy internal electronic components.

- ▶ Observe the mains voltage specification on the nameplate (→ page 11, § 7.1).

**Overheat fuse**

Type 210 is equipped with an overheat fuse which cuts off the power supply when the internal temperature exceeds 98 °C (208 °F). When the fuse is blown, the electronics board needs to be replaced for repair.

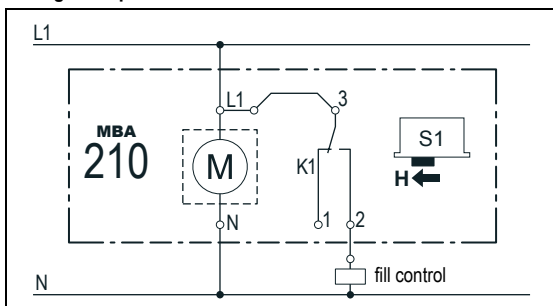
**Wiring example as FULL level indicator**

## 3.4.5 Type 220 (24 VAC/DC)

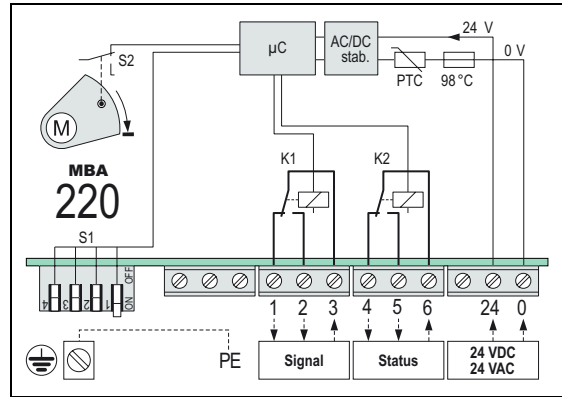
**Signal contact**

Use make&break relay contact K1 for the level indication (paddle rotating / stopped). Depending on setting of S1-1, relay K1 is activated either when the paddle is rotating or when the paddle is stopped.

- ▶ Select which setting provides a fail-safe operation in your system (→ § 3.5).

**Status contact**

Relay contact K2 is used to indicate a fault condition. Full information → page 11, § 6.

**Permissible contact load**

Direct current: 60 VDC, 1 A (DC 1)  
Alternating current: 250 VAC, 2 A (AC 15)

**Power supply**

Permissible power supply voltage:  
Direct current: 24 VDC -10 %/+30 %  
Alternating current: 24 VAC -15 %/+10 %

- ▶ Provide an external power fuse.
- ▶ Connect the power supply to terminals »24 V« (+) and »0 V« (-).
- ▶ Connect the protective earth (PE) conductor to the terminal in the unit head.

**Power overload fuse**

The power overload fuse cuts off the internal power supply in case of high current.

- ▶ *When overload fuse has been released:* Switch off the power supply externally and wait for approximately one minute for the fuse to cool down; then switch on the power supply again.
- ▶ *If the overload fuse is released again:* Search for the trouble; or replace the electronics board, if required.

**Overheat fuse**

The overheat fuse cuts off the power supply when the internal temperature exceeds 98 °C (208 °F). When this fuse is blown, the electronics board needs to be replaced for repair.

3.4.6 Type 230 (42/115/230 VAC)

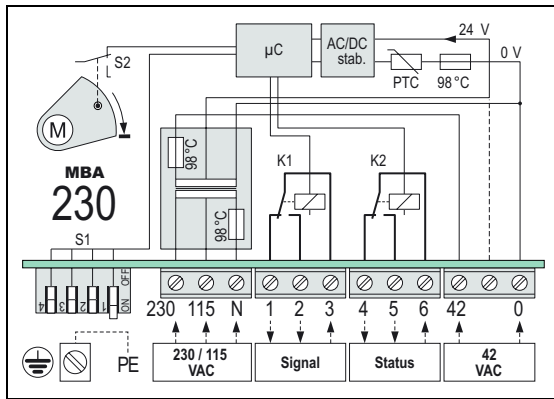

**Signal contact**

▶ See type 220.

**Status contact**

▶ See type 220.

**Permissible contact load**

▶ See type 220.

**Power supply**

- ▶ Provide an external power fuse.
- ▶ For 115 or 230 V power voltage: Connect L1 conductor to terminal »115« or »230«, respectively. Connect N conductor to terminal »N«.
- ▶ For 42 V power voltage: Connect L1 conductor to terminal »42«. Connect N conductor to terminal »0«.
- ▶ Connect the protective earth (PE) conductor to the terminal in the unit head.



**WARNUNG: Internally generated power voltage**

The power terminals »230« and »115« will have a voltage output of 230/115 V, even if the unit is used with a lower power voltage (due to power feedback through internal transformer).

- ▶ Observe this information when operating the unit with open unit head for service purposes. Take care. Give a warning to other persons.



Permissible power voltage tolerance: -15 %/+10 %

**Internal fuses**

Type 220 is equipped with three internal fuses:

- Power overload fuse: see type 220.
- Overheat fuse: see type 220.
- Overheat fuse in the power transformer: cuts off the transformer circuit at 98 °C (208 °F).

3.5 DIP switch settings for type 220/230

S1	ON	OFF
1	Fail-safe FULL indication: K1 is activated when the paddle is rotating. During power failure, the »full« status is indicated (like paddle is stopped).	Fail-safe EMPTY indication: K1 is activated when the paddle is stopped. During power failure, the »empty« status is indicated (like paddle is rotating).
2	Switch-on delay: K1 switches on with a delay of 4 s.	No electronic switch-on delay.
3	Switch-off delay: K1 switches off with a delay of 4 s.	No electronic switch-off delay.
4	The action monitoring option is built-in (consequences → page 11, »Fault indication«).	The action monitoring option is not built-in.

3.6 Closing the housing

3.6.1 Closing the cable glands

- ▶ Lay the connected cables internally in such a way that they do not interfere with the mechanism.
- ▶ After the cables have been installed, the cable glands must be closed-off to be dust-tight and spray-water resistant.
- ▶ Unused cable glands must either be blocked-off with stoppers or replaced with closing caps. If used in explosion-hazardous locations, these parts must be applicable to explosion-hazardous locations (ATEX-certified).

3.6.2 Closing the cover

- ▶ Before closing cover of the unit head, check whether there are any foreign bodies inside the unit head (such as rests of cable). Remove them.
- ▶ Visually check the sealing of the cover. Clean or replace if necessary.
- ▶ Put the cover in place and screw it up tight.

## 4 First Start-up

### 4.1 Switching on



**WARNING: Health risk / Explosion hazard**

During operation, the unit head and the cable gland(s) must be correctly closed and sealed. Otherwise the specified type of protection and the specified explosion protection (option) is not guaranteed.

### 4.2 Function test at first start-up

#### 4.2.1 Check the operative function

After the first start-up, check the indicating function:

1. Allow the paddle to rotate freely: check the »empty« indication.
2. Stop the paddle by hand: check the »full« indication.

#### 4.2.2 Check for triggering by the bulk material

**Procedure**

- ▶ While visually watching the bulk material level, fill and empty the bulk materials container up to the MBA unit, and check that the indicating function is correctly triggered. This test should be made several times.
- ▶ *If the MBA unit does not correctly indicate the level status:* Check the options for mechanical adaptation (see below) and carry them out if necessary.



*If the type of bulk material has been changed:*

- ▶ Do this test/adaptation again.

**Possible ways of adapting the unit**

- **Spring tension** (see figure):
  - More sensitive setting (less tension), for light bulk material: Bring the spring to closer position.
  - Less sensitive setting (more tension), for heavy bulk material: Bring the spring to a more distant position.
- **Paddle size:**
  - To make it more sensitive (for lighter bulk material): Install a bigger paddle.
  - To make it less sensitive: Install a smaller paddle.
- **Spring type:** If required, install a stronger or weaker spring (3 different types available).

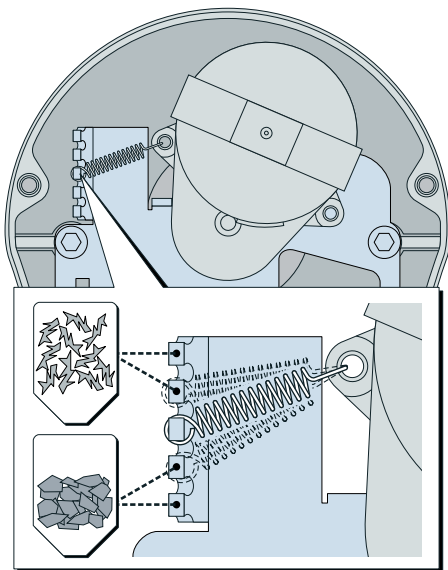

## 5 Maintenance

### 5.1 Recommended maintenance work

- ▶ **Clean the moving external parts:** Clean off deposits and dirt on paddle and shaft, using a (soft) scraper and/or a brush. Do not use force. Caution: Do not damage the shaft sealing. Do not allow bristles to get between the shaft and the shaft sealing.
- ▶ **Inspect the parts subject to wear** (highly recommended in case of abrasive bulk material): Make a visual inspection of the parts which protrude into the container (shaft, paddle, etc.). Pay special attention to the connecting parts (split-pins, etc.). Replace damaged or dubious parts.
- ▶ **Clean the protective tube** (only if the unit is equipped with an open protective tube): Clean the inside of the protective tube to make sure that the shaft can always freely rotate.
- ▶ **Clean the distance tube** (if existing – if required for explosion protection → page 7, § 3.3.4): Remove dust contamination from the distance tube.

### 5.2 Preventive function check

If the indicating function is seldom triggered during operation (e.g. if the level indicator is used as a safety switch):

1. Inform the connected stations that a test will be carried out.
2. Stop the paddle by hand / allow the paddle to rotate freely, and check the correct status indication.

### 5.3 Safety information on opening



**WARNING: Health risk / Explosion hazard**

- ▶ **Before opening the unit head:** switch-off the power supply and any connected signal voltage at an external point. (Note: the level indication is thereby disabled.)
- ▶ Only open the housing when you are absolutely sure that there is no possible danger.



**WARNING: High voltage inside the unit head (type 230)**

- In the type 230 unit head, there are always contacts with an output of 230 and 115 V, even if the unit is powered with a lower voltage (→ page 9, § 3.4.6).
- ▶ Observe this information when operating the unit with open unit head for service purposes. Take care. Give a warning to other persons.



Severe dirtiness inside the unit head can affect the proper functioning of the unit.

- ▶ Protect the inside of the unit head from getting dirty.

### 5.4 Removing the unit head (repair note)

The unit head can easily be separated from the process connection, without opening the process connection:

1. If the unit head is to be removed completely, disconnect the electric cables first.
2. Loosen the fixing screw on the underside of the unit head for approximately 3 mm (3 ... 4 turns).
3. Carefully pull the unit head from the process connection (along the direction of the shaft). This requires some strength, due to adhesion and friction of the sealing: use skilful power, but no brutal force; protect yourself against tumbling and falling in the case that the unit head goes suddenly free.

Re-assembly is made in reverse order.

## 6 Fault indication

### Operation principle of the fault status indication

MaihakMBA type 220 and 230 are equipped with the »Status« switch contact for fault indication, which is driven by relay K2. During normal operation, K2 is activated; in case of an internal fault, K2 is deactivated. This also happens during power supply failure. Please note: In fault condition, also relay K1 (which drives the »Signal« contact) is deactivated, in order to provide a fail-safe operation; however, this is only achieved if the K1 function mode is properly selected (→ page 9, § 3.5)

### Fault indication caused by action monitoring

If action monitoring is built-in (option), the following conditions will trigger the fault status indication:

- The shaft does not rotate, although the motor is not in the stop position (switch S2).  
Possibly defective: switch S2, motor, rotation sensor.
- The shaft is rotating, although the motor is in the stop position (switch S2). – Possibly defective: switch S2.
- ▶ Remedy: Check if internal micro-switches are blocked.
- ▶ *If this does not help:* Replace the unit head.

### General causes for fault indication

Without the action monitoring option, the following conditions will trigger the fault status indication:

- Power supply has failed.
  - An internal fuse is defective.
  - Action monitoring is activated although it is not built-in.
- Remedy: Correct the setting of S1-4 (→ page 9, § 3.5).

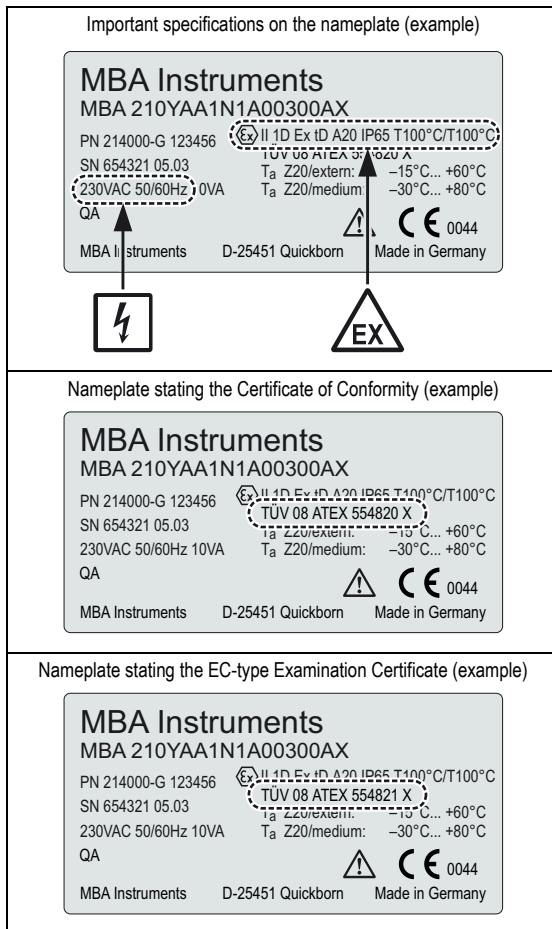

## 7 Technical data

### 7.1 Specifications on the nameplate

- Unit type (for example, »210«) and version code
- Required mains power supply (for example, »230VAC 50/60 Hz«)
- Explosion protection class (for example, »II 1D ...«), including the enclosure protection class (for example, »IP 65«) and maximum surface temperatures:
  - The first temperature value applies to the components protruding into the container.
  - The second temperature value applies to the unit head.
- Allowable ambient temperature (T<sub>a</sub>) and »Ex« zone (for example, »Z20«):
  - »extern« = for the unit head
  - »medium« = for components protruding into the container



Specifications on the nameplate apply with higher priority.

### 7.2 Electrical data

Mains voltage:	see nameplate
Tolerance:	see text in this manual
AC mains frequency:	50 ... 60 Hz
Power consumption	
– without heating:	3 VA
– with heating:	10 VA
Response time:	3 s
– quick-rotating version:	0,6 s

### 7.3 Ambient conditions

Ambient temperature outside the container

- without heating: –15 ... +60 °C (5 ... 140 °F)
- with heating: –45 ... +60 °C (–49 ... +140 °F) / –30 ... +60 °C (–22 ... +140 °F)<sup>1</sup>

Allowable temperature inside the container

- standard versions: –30 ... +80 °C (–22 ... +176 °F)
- special versions: see nameplate (→ § 7.1)

Max. surface temperature of the MBA unit:

see nameplate (→ § 7.1)

### 7.4 Product materials

#### Product materials in contact with bulk material

Enclosure, protective tube: steel/painted steel/stainless steel<sup>2</sup>, aluminium<sup>3</sup>

Sealing: Viton or PTFE<sup>2</sup> or graphite<sup>4</sup>

#### Materials of the unit head

Enclosure body: aluminium

Enclosure cover: painted aluminium

Enclosure sealing: silicone (VMQ)

Cable glands: PA (sealing: NBR) / option: nickel-plated brass (sealing: NBR/FPM, PA/PVDF)

Sealing plug: PA

Balancing membrane: polyester/ePTFE (sealing: silicone)

<sup>1</sup> in explosion-hazardous locations (→ page 13, § 7.6)

<sup>2</sup> depending on product version

<sup>3</sup> standard unit head only

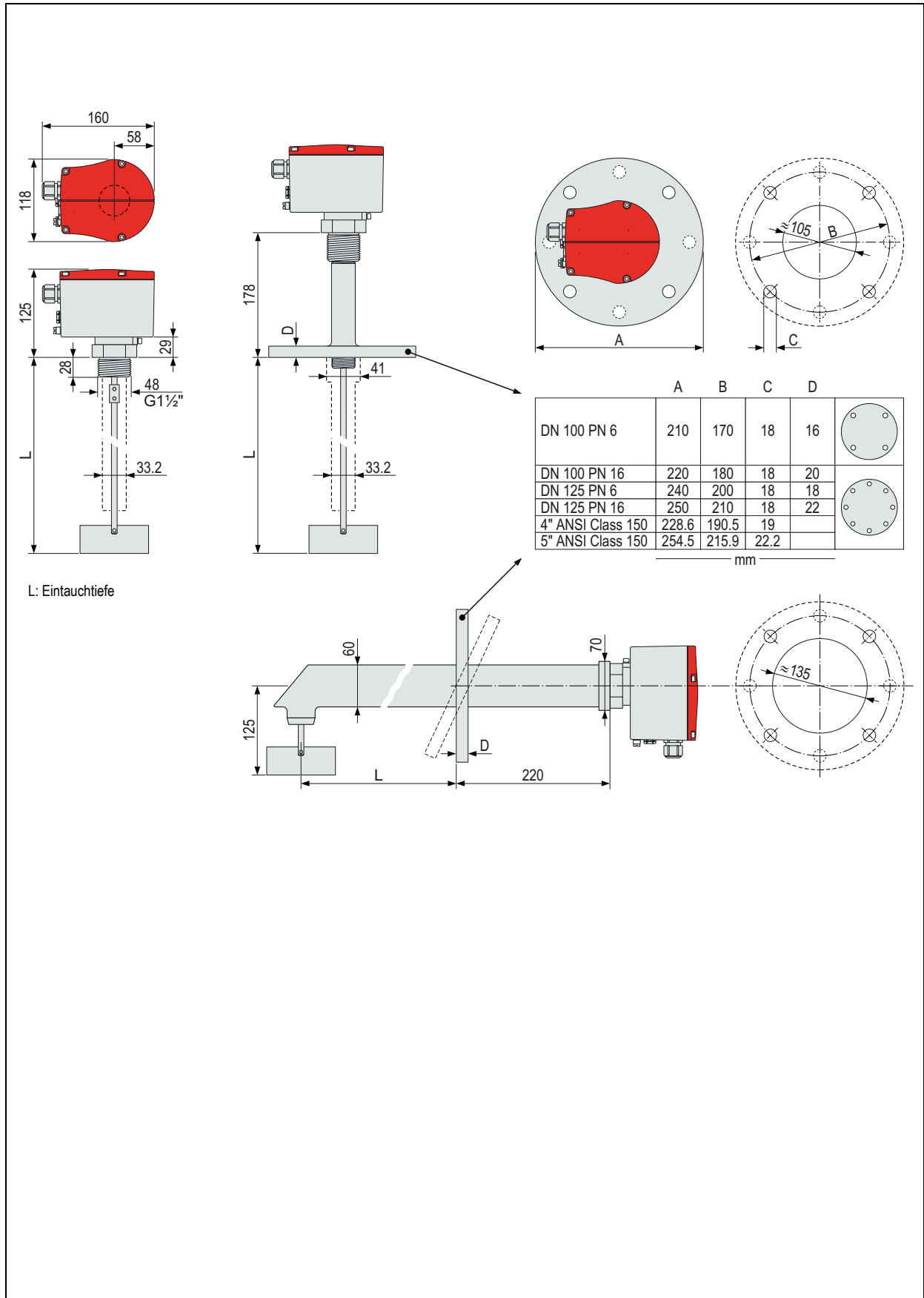

<sup>4</sup> 350 °C (660 °F) version

## 7.5 Dimensions



**EC-Type Examination Certificate**

Page 1 of 2

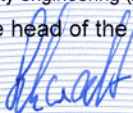
<b>Translation</b>		
(1)	<b>EC-Type Examination Certificate</b>	
(2)	Equipment and protective systems intended for use in potentially explosive atmospheres, <b>Directive 94/9/EC</b>	
(3)	<b>Certificate Number</b>	<b>TÜV 08 ATEX 554821 X</b>
(4)	for the equipment:	Rotating paddle switch type MBA 2x0 Z... and MBA 2x0 Y...
(5)	of the manufacturer:	MBA Instruments GmbH
(6)	Address:	Friedrich-List-Straße 5 25451 Quickborn Germany
	Order number:	8000554821
	Date of issue:	2008-10-08
(7)	This equipment or protective system and any acceptable variation thereto are specified in the schedule to this certificate and the documents therein referred to.	
(8)	The TÜV NORD CERT GmbH, notified body No. 0044 in accordance with Article 9 of the Council Directive of the EC of March 23, 1994 (94/9/EC), certifies that this equipment or protective system has been found to comply with the Essential Health and Safety Requirements relating to the design and construction of equipment and protective systems intended for use in potentially explosive atmospheres given in Annex II to the Directive. The examination and test results are recorded in the confidential report No. 08 203 554821.	
(9)	Compliance with the Essential Health and Safety Requirements has been assured by compliance with:	
	EN 61 241-0:2006	EN 61 241-1:2004
(10)	If the sign "X" is placed after the certificate number, it indicates that the equipment or protective system is subject to special conditions for safe use specified in the schedule to this certificate.	
(11)	This EC-type examination certificate relates only to the design, examination and tests of the specified equipment in accordance to the Directive 94/9/EC. Further requirements of the Directive apply to the manufacturing process and supply of this equipment. These are not covered by this certificate.	
(12)	The marking of the equipment or protective system must include the following:	
	 II 1/2 D Ex tD A20/A21 IP65 T100°C resp. T200°C resp. T350°C / T100 °C II 1 D Ex tD A20 IP65 T100°C resp. T200°C resp. T350°C / T100 °C	
	TÜV NORD CERT GmbH, Langemarckstraße 20, 45141 Essen, accredited by the central office of the countries for safety engineering (ZLS), Ident. Nr. 0044, legal successor of the TÜV NORD CERT GmbH & Co. KG Ident. Nr. 0032	
	The head of the certification body	
	 Schwedt	
	Hanover office, Am TÜV 1, 30519 Hanover, Fon +49 (0)511 986 1455, Fax +49 (0)511 986 1590	
	<small>This certificate may only be reproduced without any change, schedule included.          Excerpts or changes shall be allowed by the TÜV NORD CERT GmbH</small>	
	P17-F-011.06-06	page 1/2

**EC-Type Examination Certificate**

Page 2 of 2

**(13) SCHEDULE****(14) EC-Type Examination Certificate No. TÜV 08 ATEX 554821 X****(15) Description of equipment**

The rotating paddle switch type MBA 2x0 Z... and MBA 2x0 Y... is used for indication of filling limits in bulk solids.

Marking	II 1 D	II 1/2 D
Ex-area for apparatus head	Zone 20	Zone 21
Ex-area for extension with paddle	Zone 20	

**Technical data**

Permissible ambient temperature in the area of the head	-15 °C to 60 °C
Permissible ambient temperature in the area of the head with internal heating	-30 °C to 60 °C
Permissible ambient temperature in the area of the process/silo	-30 °C to 80 °C; construction for high temperatures: see „Special conditions for safe use“
Degree of protection (IP)	IP 65
Supply voltage	
Type MBA 210..., terminals L1, N, PE	230 V a. c. resp. 115 V a. c.
Type MBA 220..., terminals 24 V, 0 V	24 V a. c./d. c.
Type MBA 230..., terminals 230, 115, N, PE terminals 42, 0	230 V a. c. resp. 115 V a. c. 42 V a. c.
Contact circuits	
Terminals 1, 2, 3 and 4, 5, 6	250 V a. c., 2 A resp. 60 V d. c., 1 A

(16) The test documents are listed in the test report No. 08 203 554821.

**(17) Special conditions for safe use**

- At process temperatures > 80 °C (max. 200°C resp. max. 350°C), only the high temperature constructions of the rotating paddle switch are permissible. Then, the max. process temperature regarding the explosion hazardous dust-air mixture has to be assessed by the user. The temperature of the distance tube can exceed the max. surface temperature of the apparatus head (100°C); then, this temperature has to be assessed by the user regarding the explosion hazardous dust-air mixture. The hints in the manual of the user have to be observed.
- At risks by pendulum swinging or vibration of the extender sufficient measures have to be taken by the user against strokes towards the silo wall.
- The connection cables have to be installed fixed.

**(18) Essential Health and Safety Requirements**

no additional ones

page 2/2

Notes

# MBA 200

8011417/2009-05 (V2.2)

MBA Instruments GmbH  
Friedrich-List-Str. 5 | 25451 Quickborn | Germany | [www.mba-instruments.de](http://www.mba-instruments.de)  
Phone +49 (0) 41 06 123 888-0 | Fax +49 (0) 41 06 123 888-9 | [info@mba-instruments.de](mailto:info@mba-instruments.de)

